

# VAMP 59

## Line differential relay with IEC 61850



The VAMP 50 series protection relay family is based on proven technology concepts developed in close cooperation with customers. Vamp products have been designed around user-friendliness, a feature which is proven in our customer reports day after day.

VAMP 59 is a differential protection device mainly designed for sub-transmission overhead lines, medium voltage cables and transformers. VAMP 59 is extremely cost-effective due its flexible design.

Phase segregated protection is based on current (vector) differential. A combination of both phase and magnitude differential is used to determine operation. VAMP 59 also includes all basic back-up protection functions for differential protection.

Data communication for differential current measurement is achieved via fiber-optic cables. 1550 nm single-mode fibre optic interfaces provide communication links of up to 120km.



### CUSTOMER BENEFITS

#### Robust and flexible hardware

- Modular design with versatile hardware expansion for communication, arc protection and digital I/O extension
- Designed for demanding industrial conditions
- Automatic adaption of new / removed hardware

#### Common technology for cost efficiency

- Powerful CPU supporting native IEC 61850
- Utilisation of common VAMP platform accessories

#### User-friendly and high functionality

- Common firmware platform with VAMP 50 Series
- Phase segregated line differential (typical fault clearance time 35ms)
- Up to 16 transfer signals can be shared between the units (transfer trip possibility).
- Communication link supervision
- Feeders with in-zone transformers
- Autoreclose function

#### Modern Human Machine Interface (HMI)

- Large and clear LCD display
- Single line diagram mimic with control, indication and live measurements
- Programmable function keys and LEDs
- Standard USB connection (type B) for setting software (VAMPSET)

# VAMP 59: line differential relay with IEC 61850

## EASE OF USE

User-friendliness has always been a feature of VAMP products, and the VAMP 50 series is no exception. A great deal of effort has gone into the design of the operational aspects of the new products.

The rapid setting and download/upload is achieved with the unique VAMPSET setting software which dramatically improves usability. Unicode support allows the menu text and settings to be translated into various international languages including for example Russian and Chinese. The informative human machine interface shows all of the required information to the user with support of customised legend texts.



## VAMP 50 FAMILY HMI INTERFACE

### Navigation push buttons

### Function buttons with:

- User configurable legend texts
- CB control
- Protection setting group selection
- Freely programmable

### Programmable LEDs

- User configurable legend texts
- 12 LEDs, 2 fixed (power, error) and 8 freely programmable (2 for push buttons)

### 128 x 64 LCD dot matrix display

- Single line diagram and freely assignable analogue values
- Unicode language support

### Local port

- USB interface



The template for user legend texts is a part of the product documentation.

The texts are printed on a transparent film allowing customisation of the relay.

### Two optional module slots

- Extends the functionality of the relay
- Remote port: RS485, RS232 & Ethernet (RJ-45 or fiber)
- Arc, DI/DO



The optional DI/DO, arc connection and communication modules can be added to the basic relay later on in order to extend the functionality of the relay during its life time without firmware update.

# VAMPSET Setting and Configuration Tool

VAMPSET is a user-friendly, free-of-charge relay management software for setting parameters and configuring VAMP relays. Via the VAMPSET software, relay parameters, configurations, and recorded data can be exchanged between PC and VAMP relays. Supporting the COMTRADE format, VAMPSET also incorporates tools for analysing relay events, waveforms and trends from data recorded by the relays, e.g. during a network fault situation.

COMTRADE files can be downloaded to the memory of the relay and be played over and over again by using VAMPSET. The software also includes virtual voltage and current injection module which comes very handy at the office environment or while doing the commissioning of SCADA system.

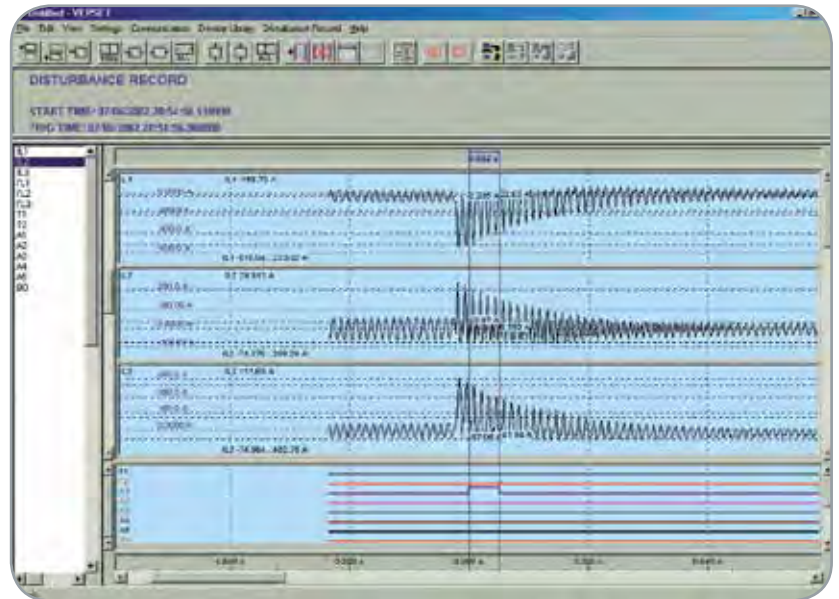

VAMP relays support standard COMTRADE type disturbance recording files which can be uploaded/downloaded for evaluation of any network event recorded.



Standard USB communication cable can be used.

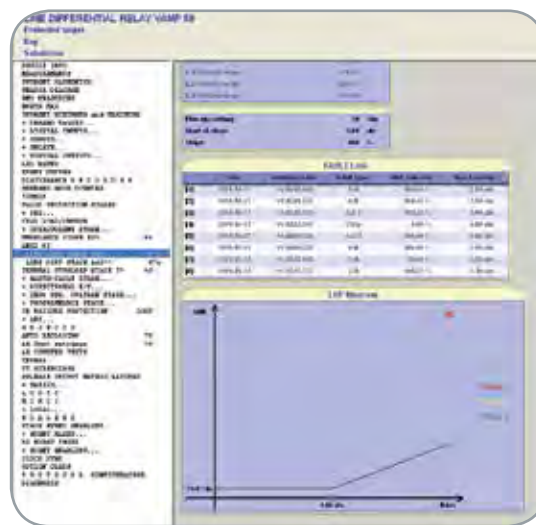

The phase sequences for currents and voltages can be read on-line from the clear and explicit phasor diagram screen for easy commissioning of the relay.

Using a standard serial cable the PC running VAMPSET connects to the front port of the VAMP relays. The VAMPSET software also supports TCP/IP communication via an optional port. Featuring true multi-language support the software runs on Windows 7 / Vista / XP / 2000 / NT and Windows 98 / 95 without any need for configuration of the PC.

**The VAMPSET software is future-proof, supporting future updates and new VAMP products.**

	VAMP 59
Analog inputs	3 x I 1 x Io, 1 x U
Digital inputs	2 (7)
Trip relays	4 (5)
Control relays	2
mA output	Option
Arc protection	Option
Front port	USB
Optional rear port	IRIG-B / RTG Fibre / Fibre / Ethernet
External RTD input module	Option

**INPUT / OUTPUT OPTIONS**  
The VAMP 59 relay hosts various optional modules in order to upgrade the relay functionality from basic to more advanced applications.

# Communication

VAMP is an expert in communication with vast experience in interfacing different system integrators, SCADA, RTUs, PLCs and gateways using a large number of supported protocols. Flexible adaptation of the communication protocols together with powerful and easy to use software tools are the key to successful integration. VAMP 59 and the VAMPSET tool provide access to practically any power system information you may need.

## NATIVE IEC 61850

The IEC 61850 protocol can be used to read or write static data or to receive events sent spontaneously from the relay. In addition, the interface allows peer-to-peer communication between the relays, known as GOOSE. The IEC 61850 interface is configured with familiar, user-friendly VAMPSET software.

The IEC 61850 datamodel, data-sets, report control blocks and GOOSE communication are configured according to the requirements of the system configuration. VAMPSET is also used to produce ICD files, which may be needed for the substation integration.

The Vamp 59 IEC61850 implementation is native, which means the functionality is integral to the product design and software, providing fast and efficient operation.



## VAMP 59 COMMUNICATION PROTOCOLS

- Modbus TCP
- DNP 3.0
- IEC 61850
- Ethernet IP
- Human-Machine-Communication, display
- Human-Machine-Communication, PC

# Measurements and condition monitoring

VAMP 59 relay offers a complete set of measurement functions for a basic line differential and transformer protection. Phase and residual current, current imbalance, system frequency and harmonics from phase currents are basic measurement functions in VAMP 59 relay. Condition monitoring continuously monitors trip circuits, breaker wear and current transformers.

Type of measurement	IEC Symbol	Protection function / measurement	VAMP59
Primary current	3I	Three-phase current	●
	I <sub>0</sub>	Residual current	●
	I <sub>2</sub>	Current imbalance	●
	IL	Average and maximum demand current	●
Voltage	U <sub>0</sub>	Zero sequence voltage	●
Frequency	f	System frequency	●
Harmonics	I	2nd to 15th and THD of phase currents	●
Analog mA output, 1 channel	AO	Any measured or calculated value, freely scalable	●

Control			
Digital inputs		Number of digital inputs (max)	7
Output relays		Number of trip relays (max)	5
		Number of control relays (max)	1
Object status indication		Single line diagram, 8 objects	●
Local and remote control		Number of controllable objects	6
Interlocking and logic		Configurable	●

Condition monitoring			
Trip circuit	TCS	Trip Circuit Supervision	●
	TCS	Trip Circuit Supervision with DI for T5 (optional)	●
CT Supervision		CT Supervision	●
CB wear		Breaker wear	●

# Protection stages

User-friendliness is also a built-in feature of protection stages, where setting views are graphically displayed in the relay and VAMPSET HMI. Disabled protection stages are hidden from the menu in order to display only the necessary information. Protection stages come with two setting groups to enable automatic transfer from main setting to alternative setting. This change can be universal for the entire relay or based on protection function.

The relay has a large number of standard inverse curves to adopt various protection requirements. Unique protection curves can be applied when standard IEC or IEEE curves do not provide required protection selectivity.

Type of fault	IEEE Device No.	IEC Symbol	Protection function/measurement	VAMP 59
Differential	87L	Ldl >	Phase segregated current differential, definite time	●
	87L	Ldl >>	Phase segregated current differential, definite time	●
Short circuit	50/51	I >	Three-phase non-directional overcurrent, definite or inverse time	●
	50/51	I>> I>>>	Phase segregated current differential, definite time	●
Earth-fault	50N/51N	3I <sub>0</sub> > / SEF	Non-directional earth-fault, low-set stage, sensitive, definite or inverse time	●
	50N/51N	3I <sub>0</sub> >> 3I <sub>0</sub> >>> 3I <sub>0</sub> >>>>	Three phase non directional overcurrent, definite time	●
	67N or 50N/51N	3I <sub>0q</sub> > / SEF	Directional or non dir. earth-fault, low-set stage, sensitive, definite or inverse time	●
	67N or 50N/51N	3I <sub>0q</sub> >>	Directional or non dir. earth-fault, high-set stage, definite or inverse time	●
	59N	U <sub>0</sub> >	Zero sequence voltage, low-set stage	●
	59N	U <sub>0</sub> >>	Zero sequence voltage, low-set stage	●
Overload	49	T>	Three-phase thermal overload	●
Arc flash protection	50ARC/50NARC	3 I <sub>a</sub> / I <sub>0</sub> >, L>	Electrical arc flash protection stage, point sensors, optional	●
Other functions	79	O --> I	Auto-reclosing, three pole tripping	●
	68	If2>	2nd harmonic restraint	●
		If5>	5th harmonic blocking	●
	46	I <sub>2</sub> >	Phase unbalance protection	●
	86		Latched trip	●
	50BF	CBFP	Circuit breaker failure protection	●
	99		8 Programmable stages	●
		DR	Disturbance recorder	●

## Arc flash protection

The arc flash connection interface is supported throughout entire Vamp's current measuring relay range. The typical arc protection application for VAMP 59 is to place an arc sensor in the cable termination compartment. With this arrangement a possible arc flash fault in the cable termination can be distinguished within 7 ms.

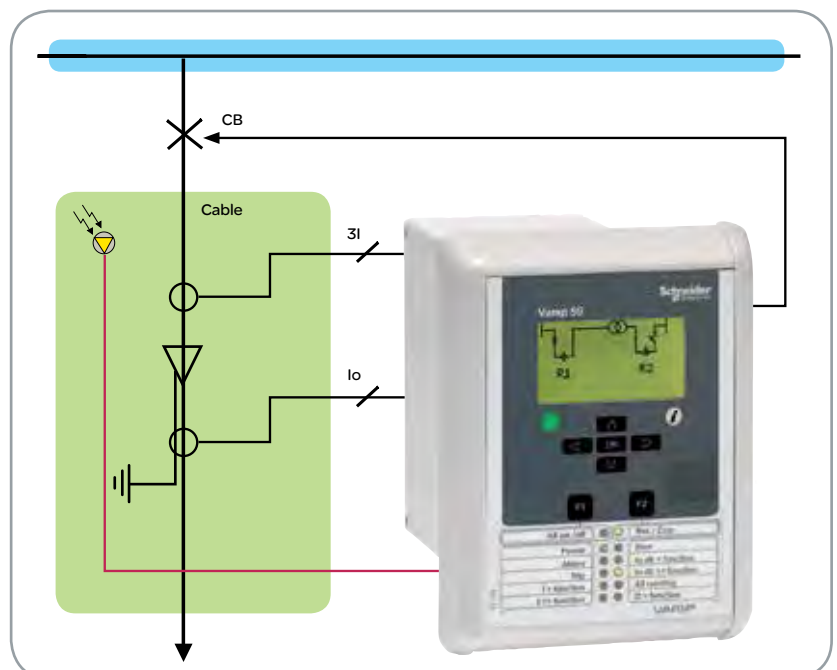

The optional integrated arc protection system may extend the life time of the switchgear.

# Product highlights

VAMP 59 is a line protection relay built for medium voltage overhead lines and cable protection. Versatile firmware of VAMP 59 creates the possibility to also use the relay in applications with in-zone transformers. The relay includes back-up protection functions for basic overcurrent and earth fault functions with three phase autoreclose. VAMP 50 series relay design makes this unit cost efficient, user-friendly and easy to use. Flexible hardware design allows simple addition of integrated optional modules like arc sensor interface, extension of DI / DO channels and various communication modules.

Programmable stages enable the user to configure new protection elements and create new triggering conditions in the disturbance recorder.



## LINE DIFFERENTIAL CHARACTERISTICS

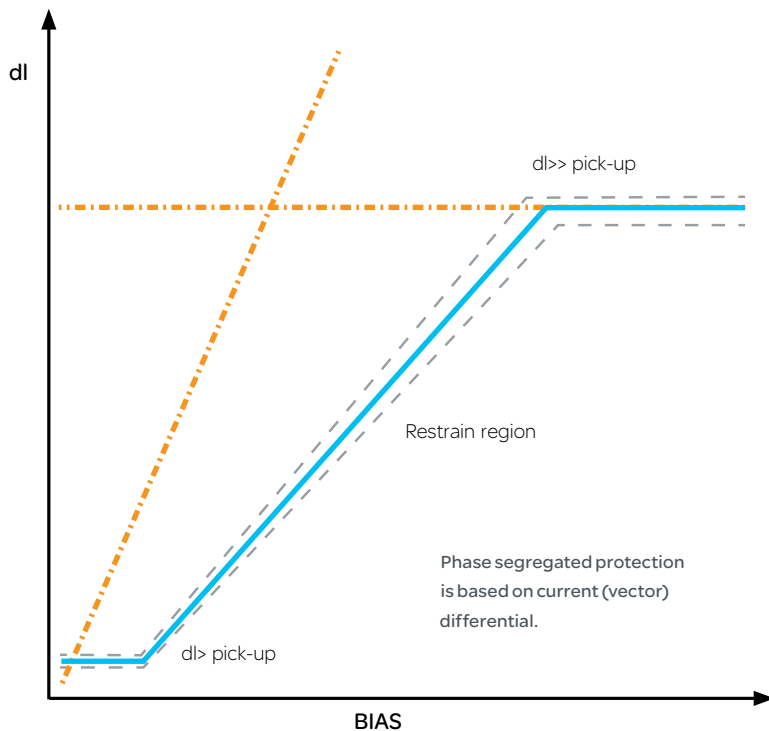

## POC-SIGNALS

**PROCES CONFIGURATION**

Block Instance: [ ] All Protected [x]

**POC SIGNALS**

Name	Configuration	Signal	Index	Out Event	Out Count
POC1	None	DI	1	DI	DI
POC2	None	DI	2	DI	DI

↓

**OUTPUT MATRIX**

\* connected  
 @ connected and latched

	T1	T2	T3	T4	A1	B0
POC1	@					
POC2						
POC3						
POC4						

It is possible to send 16 self-programmed messages between VAMP 59 units. Signal transfer of these POC-messages takes approximately 10-20ms + additional DI/DO activation delay

## AUTORECLOSE

VAMP 59 is equipped with an autoreclose function. The relays operate with a master and slave principle, when the master performs autoreclose, the slave unit waits for permission to close the breaker after successful reclosing. Breaker close signal can be sent to the other unit as a POC message.

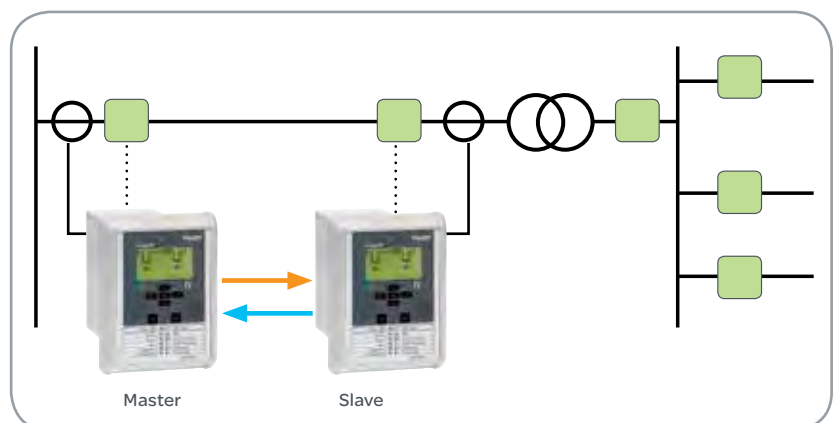

# VAMP 59 connection diagram

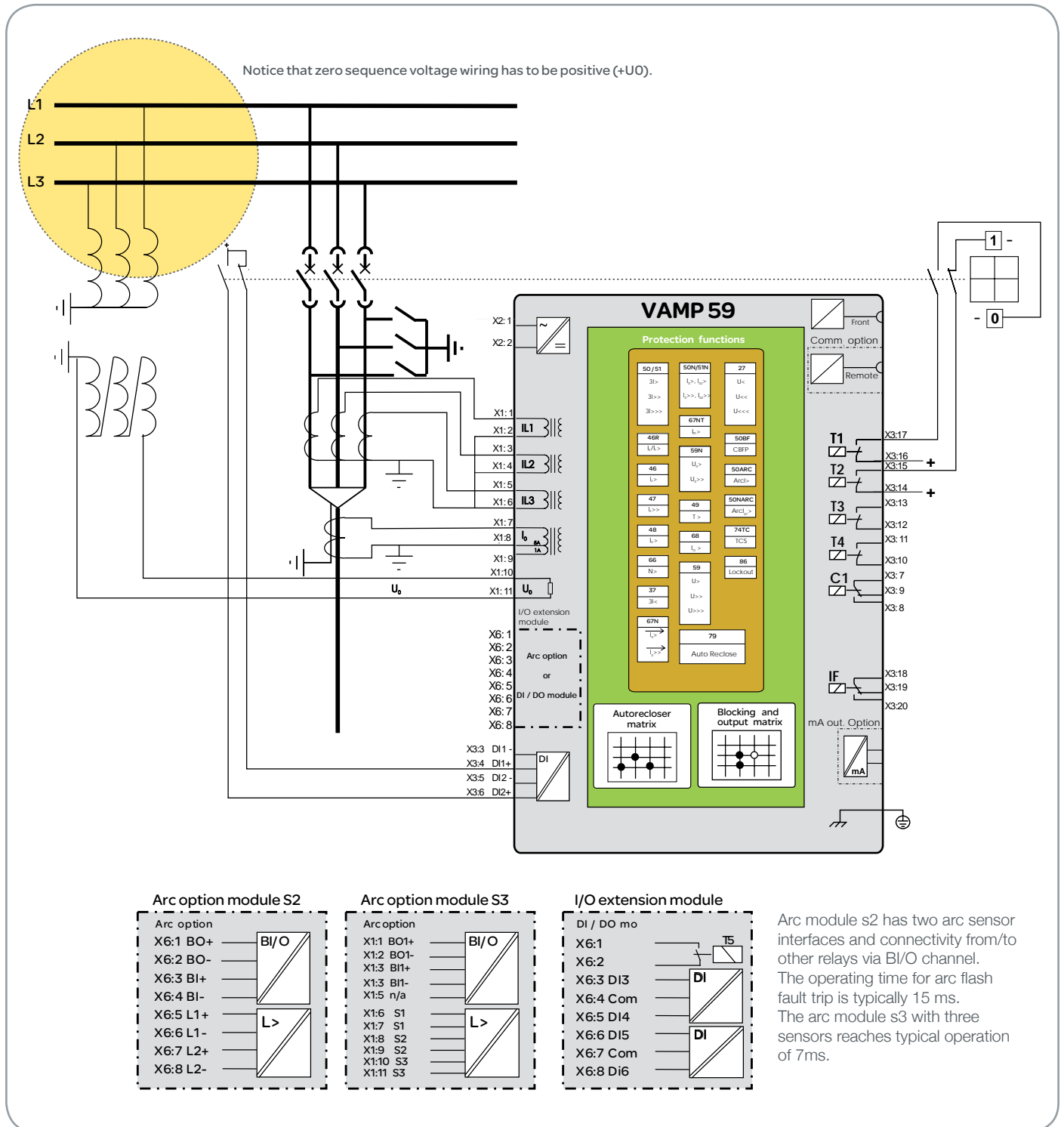

# Dimensional drawings

## VAMP 59

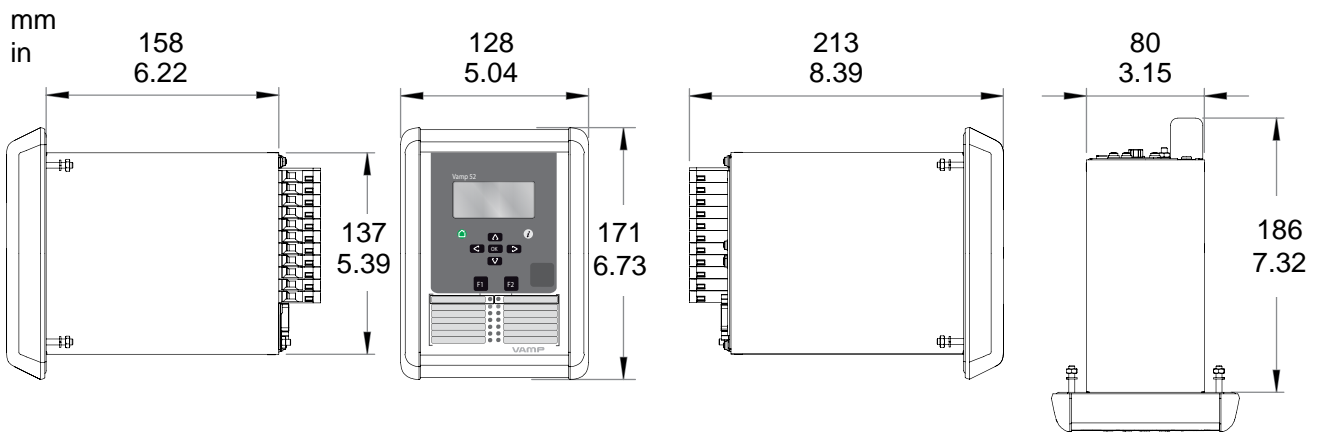

## Panel mounting technique

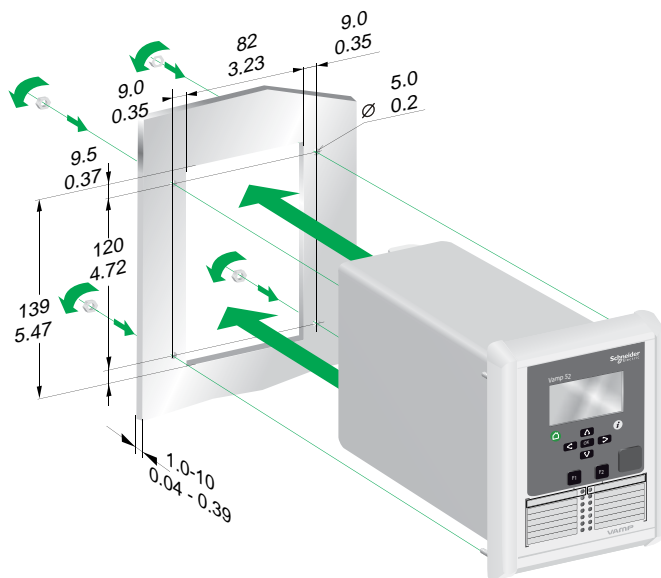



# Main technical data

Auxiliary voltage	
Voltage range	40...265 V ac / dc (option A) 18...36 V dc (option B)

Measuring circuit	
Rated phase current $I_N$	1/5A
Current measuring range	0.005...50 x $I_N$
Rated neutral current $I_{0N}$	1 A or 5 A (optionally 0.2 A or 1 A)
Current measuring range	0.003...10 x $I_N$
Thermal withstand	4 x $I_N$ (continuous) 100 x $I_N$ (for 1 s)
Rated frequency $f_N$	50 / 60 Hz (45...65 Hz)

I/O	
Digital inputs (external voltage)	2 pcs (7 option)
Selectable nominal voltage (threshold)	24 / 110 / 220 V ac / dc
Trip contacts	4 pcs (5 option)

## Disturbance tests

	Standard & Test class / level	Test value
<b>Emission</b>	<b>EN 61000-6-4 / IEC 60255-26</b>	
Conducted	EN 55011 class A / IEC 60255-25	0.01 - 30 MHz
Emitted	EN 55011 class A / IEC 60255-25 / CISPR 11	30 - 1 000 MHz
<b>Immunity</b>	<b>EN 61000-6-2 / IEC 60255-26</b>	
1Mhz damped oscillatory wave	IEC 60255-22-1	± 2.5kVp CM, ± 1kVp DM
Static discharge (ESD)	EN 61000-4-2 class IV / IEC 60255-22-2 Class IV	8 kV contact, 15 kV air
Fast transients (EFT)	EN 61000-4-4 Level IV / III / IEC 60255-22-4 class A / B	14 kV / (12 kV signal ports), 5/50 ns, 5 kHz
Surge	EN 61000-4-5 class III / IEC 60255-22-5	2 kV, 1.2/50 ms, CM 1 kV, 1.2/50 ms, DM
Conducted HF field	EN 61000-4-6 class III / IEC 60255-22-6	0.15 - 80 MHz, 10 Vemf
Emitted HF field	EN 61000-4-3 class III / IEC 60255-22-3	80 - 2700 MHz, 10 V/m
Voltage interruptions	EN 61000-4-29 / IEC 60255-11	30%/1s, 60%/0.1s, 100%/0.05s
Voltage alternative component	EN 61000-4-17 / IEC 60255-11	12% of operating voltage (DC) / 10min
Voltage dips and short interruptions	EN 61000-4-11	30%/10ms, 100%/10ms, 60%/100ms >95%/5000ms
Power-frequency magnetic field	EN 61000-4-8	300A/m (continuous), 1000A/m / 1-3s
Pulse magnetic field	EN 61000-4-9 Level V	1000A/m, 1.2/50 ms

## Electrical safety tests

	Standard & Test class / level	Test value
Impulse voltage withstand	EN 60255-5, class III	5 kV, 1.2/50 ms, 0.5 J
Dielectric test	EN 60255-5, class III	2 kV, 50 Hz
Insulation resistance	EN 60255-5	
Protective bonding resistance	EN 60255-27	
Power supply burden	IEC60255-1	

## Mechanical tests

	Standard & Test class / level	Test value
<b>Device in operation</b>		
Vibrations	IEC 60255-21-1, class II / IEC 60068-2-6, Fc	1Gn, 10Hz – 150 HZ
Shocks	IEC 60255-21-2, class II / IEC 60068-2-27, Ea	10Gn/11ms
<b>Device de-energized</b>		
Vibrations	IEC 60255-21-1, class II / IEC 60068-2-6, Fc	2Gn, 10Hz – 150 HZ
Shocks	IEC 60255-21-2, class II / IEC 60068-2-27, Ea	30Gn/11ms
Bump	IEC 60255-21-2, class II / IEC 60068-2-27, Ea	20Gn/16ms

## Environmental tests

	Standard & Test class / level	Test value
<b>Device in operation</b>		
Dry heat	EN / IEC 60068-2-2, Bd	+65°C
Cold	EN / IEC 60068-2-1, Ad	-40°C
Damp heat, cyclic	EN / IEC 60068-2-30, Db	From +25°C to +40°C, From 93% RH to 98% RH, 6 days
Damp heat, static	EN / IEC 60068-2-78, Cab	+40°C, 93% RH, 10 days
Flowing mixed gas corrosion test, method 2	IEC 60068-2-60, Ke	+25°C, 75% RH, 10 ppb H <sub>2</sub> S, 200 ppb NO <sub>2</sub> , 10 ppb Cl <sub>2</sub>
Flowing mixed gas corrosion test, method 4	IEC 60068-2-60, Ke	+25°C, 75% RH, 10 ppb H <sub>2</sub> S, 200 ppb NO <sub>2</sub> , 10 ppb Cl <sub>2</sub> , 200 ppb SO <sub>2</sub>
<b>Device in storage</b>		
Dry heat	EN / IEC 60068-2-2, Bb	+75°C
Cold	EN / IEC 60068-2-1, Ad	-40°C

## Environmental conditions

Ambient temperature, in-service	-40...+60°C
Ambient temperature, storage	-40...+70 °C
Relative humidity	< 95%, no condensation allowed
Maximum operating altitude	2000 m
Degree of protection (IEC 60529)	IP54

## Casing

	Standard & Test class / level
Degree of protection (IEC 60529)	IP54
VAMP 50 dimensions (W x H x D)	130 x 170 x 210 mm / 5.11 x 6.69 x 8.26 inches
Material	1 mm / 0.04 inches steel plate
Weight	2.0 kg
Colour code	RAL 7032 (Casing) / RAL 7035 (Back plate)

## Package

	Standard & Test class / level
Dimensions (W x H x D)	230 x 215 x 175 mm / 9.05 x 8.46 x 6.89 inches
Weight (Terminal, Package and Manual)	3.0 kg

# Order codes

V59 -         -



<b>Phase current inputs [A]</b>
<b>3</b> = 5 A
<b>Earth-fault current input [A]</b>
<b>A</b> = 1 A / 5 A
<b>B</b> = 0.2 A / 1 A
<b>Supply Voltage [V]</b>
<b>A</b> = 40.. 265 Vac / dc
<b>B</b> = 18 ... 36 Vdc
<b>mA output option</b>
<b>A</b> = None
<b>B</b> = mA output
<b>DI nominal activation voltage</b>
<b>1</b> = 24 Vdc / 110 Vac
<b>2</b> = 110 Vdc / 220Vac
<b>3</b> = 220 Vdc
<b>Optional I/O extension modules</b>
<b>A</b> = None
<b>B</b> = Digital I/O; 4 x DI, 1 x DO
<b>C</b> = Arc protection; 2 x Sensor, BIO
<b>D</b> = Arc Protection; 3xSensor +BI + BO
<b>Optional communication module 1</b>
<b>L</b> = RS-232 interface with option for module 2
<b>Optional communication module 2</b>
<b>A</b> = None
<b>B</b> = IRIG-B time synchronisation input
<b>C</b> = RTD interface (Glass fibre)
<b>E</b> = RJ-45 10 Mbps ethernet interf. inc. IEC 61850
<b>G</b> = LC 100 Mbps ethernet fibre interf. inc. IEC 61850
<b>PCP coating</b>
= None
<b>C</b> = Conformal coating

Optional cards can be ordered separately:

Order code	Description
5VOM Arc+BI	ARC option card (2S+BI+BO)
5VOM Arc+3S	ARC option card (3S+BI+BO)
5VOM4DI1DO	Digital Input / Output option card

Accessories

Order code	Description	Note
VSE001GG	Fiber optic Interface Module (glass - glass)	Max. distance 1 km
3P032	WESTERMO ODW-720-F1	(Base module)
3P033	WESTERMO SLC20 (1310 nm)	Max. Distance 20 km
3P034	WESTERMO SLC40 (1310 nm)	Max. Distance 40 km
3P035	WESTERMO SLC80 (1550 nm)	Max. Distance 80 km
3P036	WESTERMO SLC120 (1550 nm)	Max. Distance 120 km
VX063	RS232 converter cable for WESTERMO ODW-720-F1	Cable length 3m
3P014	MOXA TCF-90	Max. distance 40 km
VX048	RS232 converter cable for MOXA TCF-90	Cable length 3 m
3P022	MOXA TCF-142-S-ST	Max. distance 40 km
VX062	RS232 converter cable for MOXA TCF-142-S-ST	Cable length 3 m
VX052-3	USB programming cable (Vampset)	Cable length 3 m
VX044	Interface cable to VIO 12 (RTD module)	Cable length 2m
VIO 12 AA	RTD Module, 12pcs RTD inputs, Optical Tx Communication (24-230 Vac/dc)	
VIO 12 AC	RTD/mA Module, 12pcs RTD inputs, PTC, mA inputs/outputs, RS232, RS485 and Optical Tx/Rx Communication (24 Vdc)	
VIO 12 AD	RTD/mA Module, 12pcs RTD inputs, PTC, mA inputs/outputs, RS232, RS485 and Optical Tx/Rx Communication (48-230 Vac/dc)	
VA1DA-6	Arc sensor	Cable 6 m
VA1DA-20	Arc sensor For default model	Cable 20 m
V50WAF	V50 wall assembly frame	



DEVICE TRACK RECORD

- Schneider Electric's VAMP range specialises in protection relays, arc flash protection and measuring and monitoring units for power systems.
- VAMP's medium-voltage and sub-transmission protection relays are used in numerous applications, from overhead line feeders and substations to power plants and industrial power system. Their unique integrated arc flash fault protection functionality enhances the safety of both people and property and has made VAMP a leading range in arc flash protection worldwide. VAMP products meet international standards and regulations.

Schneider Electric Industries SAS

35, rue Joseph Monier  
 CS 30323  
 F - 92506 Rueil Malmaison Cedex (France)  
 Tel.: +33 (0) 1 41 29 70 00  
 RCS Nanterre 954 503 439  
 Capital social 896 313 776 €  
 www.schneider-electric.com

As standards, specifications and designs change from time to time, please ask for confirmation of the information given in this publication.

Design: Schneider Electric Industries SAS - Sonovision  
 Photos: Schneider Electric Industries SAS  
 Printed: Altavia Connexion - Made in France



This document has been printed on recycled paper.