

SIPROTEC 5 Devices and Fields of Application

Line Differential Protection – SIPROTEC 7SD87

Description

The SIPROTEC 7SD87 differential protection is suitable for the selective protection of overhead lines and cables with single-ended and multi-ended infeed of all lengths with up to 6 ends. Transformers and compensating coils in the protection range are also possible. With its modular structure, flexibility and the powerful DIGSI 5 engineering tool, SIPROTEC 7SD87 offers future-oriented system solutions with high investment security and low operating costs.

Main function	Differential protection
Tripping	1-pole and 3-pole, minimum tripping time: 9 ms
Inputs and outputs	12 predefined standard variants with 4/4 or 8/8 current/voltage transformers, 5 to 31 binary inputs, 8 to 46 binary outputs
Hardware flexibility	Flexibly adjustable I/O quantity structure within the scope of the SIPROTEC 5 modular system
Housing width	1/3 × 19" to 2/1 × 19"

Functions

DIGSI 5 permits all functions to be configured and combined as required.

- Minimum tripping time: 9 ms
- Main protection function is differential protection with adaptive algorithm for maximum sensitivity and stability even with the most different transformer errors, current-transformer saturation and capacitive charging currents
- Directional backup protection and various additional functions
- Recognition of static, intermittent and transient ground faults (fleeting contact function) in arc-suppression-coil-ground and isolated power systems
- Detection of current-transformer saturation
- Arc protection
- Power protection, configurable as active or reactive power protection
- Reactive power-undervoltage protection (QU protection)
- Detection of current and voltage signals up to the 50th harmonic with high accuracy for selected protection functions (such as thermal overload protection) and operational measured values
- 1-/3-pole automatic reclosing function
- Control, synchrocheck and switchgear interlocking protection
- Graphical logic editor to create powerful automation functions in the device
- Single line representation in small or large display
- Integrated electrical Ethernet RJ45 for DIGSI 5 and IEC 61850 (reporting and GOOSE)
- Up to 4 optional pluggable communication modules, usable for different and redundant protocols (IEC 61850, IEC 60870-5-103, IEC 60870-5-104, Modbus TCP, DNP3 (serial and TCP))



[SIP5_GD_W3, 1, --]

Figure 2.7/6 SIPROTEC 7SD87

- Serial protection data communication via optical fibers, two-wire connections and communication networks (IEEE C37.94, and others), including automatic switchover between ring and chain topology
- Redundancy protocols PRP and HSR
- Cyber security in accordance with NERC CIP and BDWE White-paper requirements
- Phasor measurement unit (PMU) for synchrophasor measured values and IEEE C37.118 protocol
- Time synchronization using IEEE 1588
- Powerful fault recording (buffer for a max. record time of 80 s at 8 kHz or 320 s at 2 kHz)
- Auxiliary functions for simple tests and commissioning
- Flexibly adjustable I/O quantity structure within the scope of the SIPROTEC 5 modular system

Applications

- Line protection for all voltage levels with 1-pole and 3-pole tripping
- Phase-selective protection of overhead lines and cables with single-ended and multi-ended infeed of all lengths with up to 6 line ends
- Also used in switchgear with breaker-and-a-half configuration
- Transformers and compensating coils in the protection range are possible
- Detection of ground faults in isolated or arc-suppression-coil-ground power systems in star, ring, or meshed arrangement
- Protection data communication over different distances and physical media, such as optical fiber, two-wire connections, and communication networks
- Phasor measurement unit (PMU).

SIPROTEC 5 Devices and Fields of Application

Line Differential Protection – SIPROTEC 7SD87

Application templates

Application templates are available in DIGSI for standard applications. They comprise all basic configurations and default settings.

The following application templates are available:

- Basic differential protection
- Differential protection for overhead line
- Differential protection for overhead line, for applications with breaker-and-a-half schemes.

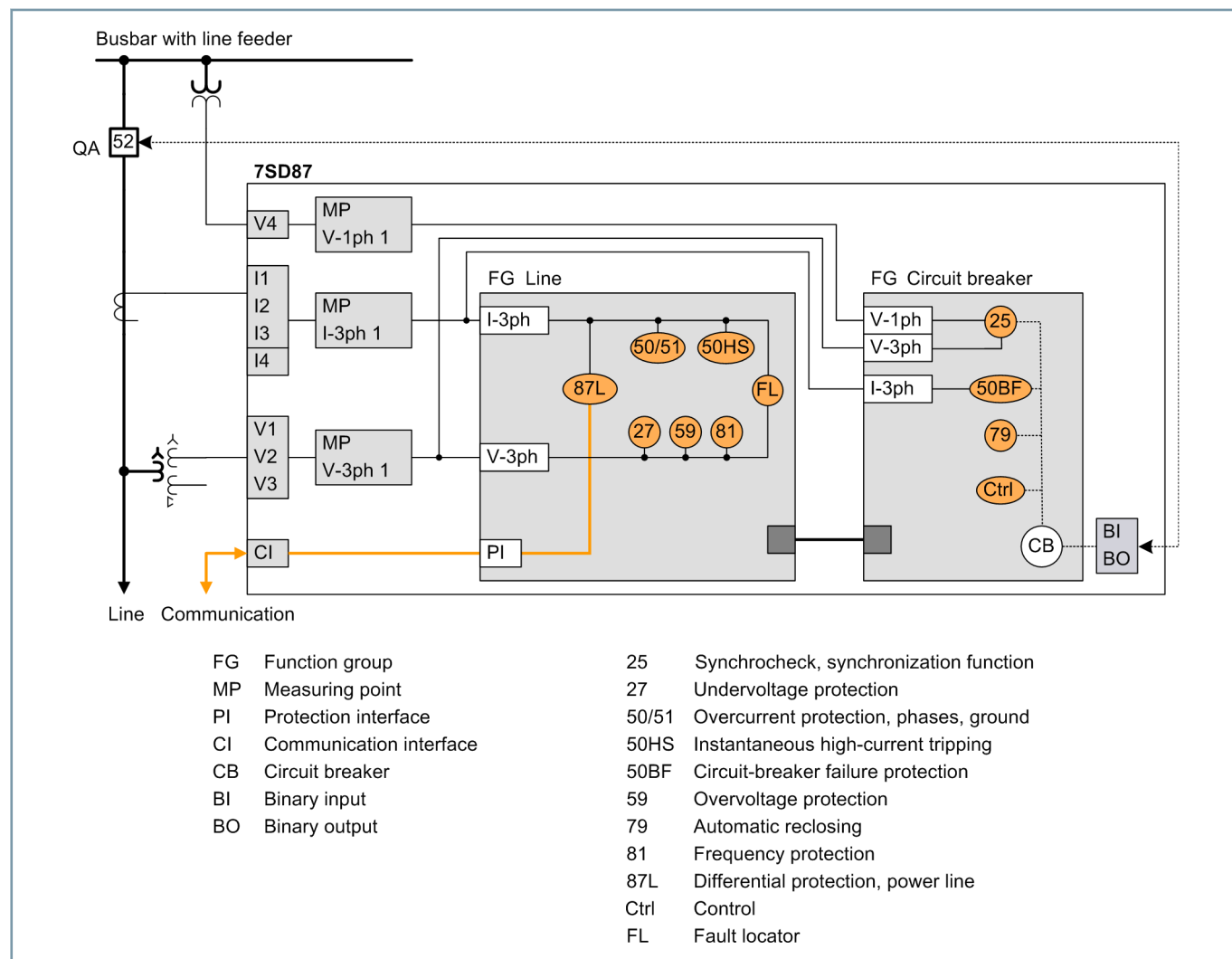

[dw_7SD87_Ltg, 1, en_US]

Figure 2.7/7 Application example: Line differential protection for overhead line

SIPROTEC 5 Devices and Fields of Application

Line Differential Protection – SIPROTEC 7SD87

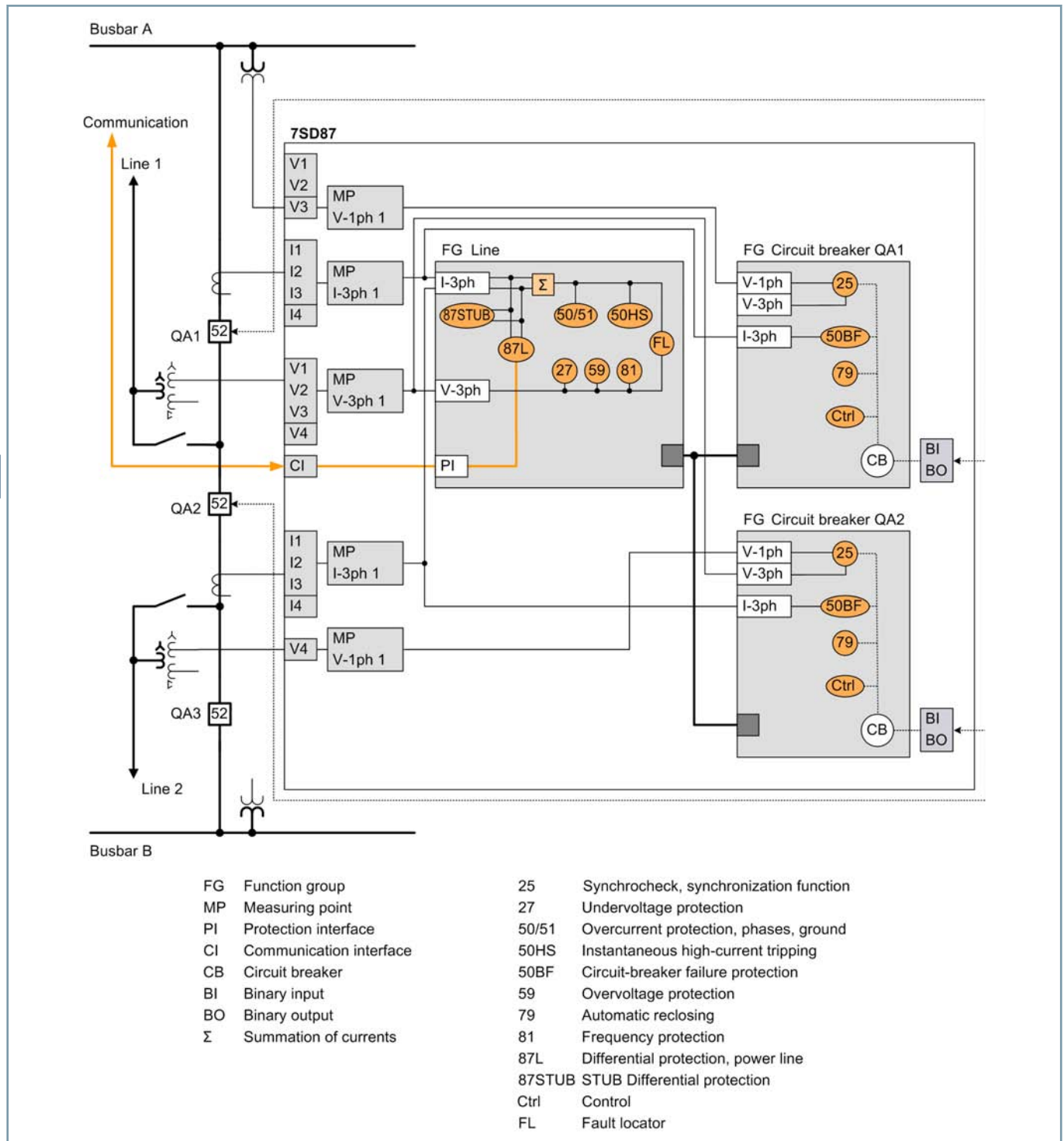

Figure 2.7/8 Application example: Line differential protection for overhead line with breaker-and-a-half scheme

SIPROTEC 5 Devices and Fields of Application

Line Differential Protection – SIPROTEC 7SD87

Functions, application templates

ANSI	Functions	Abbr.	Available	Template		
				1	2	3
	Protection functions for 3-pole tripping	3-pole	■	■	■	■
	Protection functions for 1-pole tripping	1-pole	■	■	■	■
	Hardware quantity structure expandable	I/O	■	■	■	■
87L	Line differential protection for 2 line ends	ΔI	■	■	■	■
87L	Line differential protection for 3 to 6 line ends (dependent on Significant properties)	ΔI	■	■	■	■
25	Synchrocheck, synchronizing function	Sync	■		■	■
27	Undervoltage protection: "3-phase" or "pos.seq. V1" or "universal Vx"	V<	■			
	Undervoltage-controlled reactive power protection	$Q>/V<$	■			
32, 37	Power protection active/reactive power	$P<>, Q<>$	■			
37	Undercurrent	I<	■			
38	Temperature Supervision	$\theta>$	■			
46	Negative sequence overcurrent protection with direction	$I2>, \angle(V2,I2)$	■			
47	Overvoltage protection, negative-sequence system	V2>	■			
49	Thermal overload protection	θ, I^2t	■		■	■
50/51 TD	Overcurrent protection, phases	I>	■	■	■	■
50N/ 51N TD	Overcurrent protection, ground	IN>	■	■	■	■
50HS	High speed instantaneous overcurrent protection	I>>>	■	■	■	■
	Instantaneous tripping at switch onto fault	SOTF	■			
50N/ 51N TD	Overcurrent protection, 1-phase	IN>	■			
50Ns/ 51Ns	Sensitive ground-current protection for systems with resonant or isolated neutral	INs>	■			
	Intermittent ground fault protection	lie>	■			
50BF	Circuit-breaker failure protection, 1-/3-pole	CBFP	■		■	■
51V	Voltage dependent overcurrent protection	$t=f(I,V)$	■			
59, 59N	Overvoltage protection: "3-phase" or "zero seq. V0" or "pos.seq. V1" or "universal Vx"	V>	■			
67	Directional overcurrent protection, phases	$I>, \angle(V,I)$	■			
67N	Directional overcurrent protection for ground faults in grounded systems	$IN>, \angle(V,I)$	■			
67Ns	Dir. sensitive ground-fault detection for systems with resonant or isolated neutral incl. a) $3I0>$, b) $V0>$, c) Cos/SinPhi , d) Transient fct., e) $\text{Phi}(V,I)$, f) admittance		■			
	Directional intermittent ground fault protection	lie dir>	■			
74TC	Trip circuit supervision	TCS	■			
79	Automatic reclosing, 1-/3-pole	AR	■		■	■
81	Frequency protection: "f>" or "f<" or "df/dt"	$f>,<; df/dt>,<$	■			
86	Lockout		■		■	■
87N T	Restricted ground-fault protection	ΔIN	■			
87L/ 87T	Option for line differential protection: including power transformer	ΔI	■			
	Option for line differential protection:charging-current compensation	ΔI	■			
	Broken-wire detection for differential protection		■			
87 STUB	STUB Differential protection (for one-and-half circuit-breaker applications)		■			■
90V	Automatic voltage control for 2 winding transformer		■			

SIPROTEC 5 Devices and Fields of Application

Line Differential Protection – SIPROTEC 7SD87

ANSI	Functions	Abbr.	Available	Template		
				1	2	3
90V	Automatic voltage control for 3 winding transformer		■			
90V	Automatic voltage control for grid coupling transformer		■			
FL	Fault locator, single-ended measurement	FL-one	■	■	■	■
PMU	Synchrophasor measurement (1 PMU can be used for max. 8 voltages and 8 currents)	PMU	■			
AFD	Arc-protection (only with plug-in module ARC-CD-3FO)		■			
	Measured values, standard		■	■	■	■
	Measured values, extended: Min, Max, Avg		■			
	Switching statistic counters		■	■	■	■
	Circuit breaker wear monitoring	$\Sigma I_x, I^2t, 2P$	■			
	CFC (Standard, Control)		■	■	■	■
	CFC arithmetic		■			
	Switching sequences function		■			
	Inrush current detection		■	■	■	■
	External trip initiation		■	■	■	■
	Control		■	■	■	■
	Fault recording of analog and binary signals		■	■	■	■
	Monitoring and supervision		■	■	■	■
	Protection interface, serial		■	■	■	■
	Circuit Breaker		■	■	■	■
	Disconnecter		■			■
	Region France: Overload protection for lines and cables 'PSL-PSC'		■			
	Region France: Overcurrent protection 'MAXI-L'		■			
	Region France: Net decoupling protection 'PDA'		■			
	Region France: Overload protection for transformers		■			
Function-points class:				0	150	325
The configuration and function points for your application can be ascertained in the SIPROTEC 5 order configurator under: www.siemens.com/siprotec						

Table 2.7/3 SIPROTEC 7SD87 - Functions and application templates

- 1 DIFF Basic
- 2 DIFF overhead line
- 3 DIFF overhead line, 1.5 CB